



Congratulations on the purchase of your new poly lumber side table. These easy step-by-step instructions can be used for assembling either the

Coastal 4-Plank Side Table (shown)

or

Coastal 6-Plank Side Table.

Important

Please Read All Instructions Carefully Before Assembling This Product

- Inspect all parts to make sure that nothing is broken or missing. If something is broken or missing, please contact our service department at support@eccboutdoor.com.
- The side table must be completely assembled before attempting to use it. Failure to do so could result in damage to the table or the user.
- Use proper safety gear and follow appropriate safety precautions when assembling this product.
- **Important - Do not overtighten the screws.**
- Only hand tools should be used for assembly. Do not use power tools.
- ECCB Outdoor will not be liable for any injury or damage resulting from improper assembly and/or use of this product.
- Failure to follow all instructions will result in the product warranty being voided.

Parts

Make sure you have received everything. If anything is missing or damaged, please contact our service department at support@eccboutdoor.com.

(A) Table Top - 1 piece

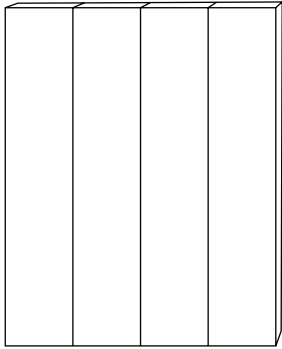

(B) Bottom Shelf - 1 piece

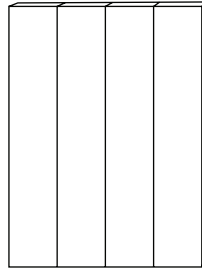

(C) Legs - 2 pieces

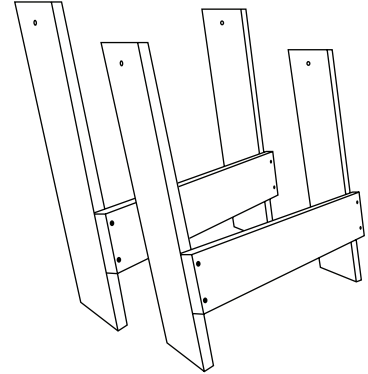

Hardware - Shown at Actual Size

(D) Bolts - 4 pieces



(E) Washers - 4 pieces



(F) Nuts - 4 pieces



Important: When attaching the nuts, ALWAYS start with the metal part screwing onto the bolt/screw. Starting with the plastic part will not work and may cause the chair not to be properly assembled. See illustration to the right.



Tools - Provided



Wrench

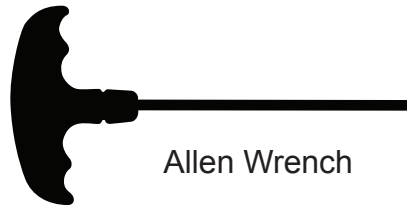

Allen Wrench

Care

Poly lumber is easy to clean and maintain. Dust with a soft cloth or soft bristle brush, and tend to spills and stains with a mild soap and water. No waterproofing, no staining, and no painting is ever required! **IMPORTANT!** Periodically check to make sure that all screws are properly tightened.

That's all there is to it and now you have a great side table that we hope you will enjoy. Thank you for your business!

Let's Get Started!

Step 1 - Attaching the Legs

- Start with the bottom of table top (A), facing up.
- Line up the legs (C) with the pre-drilled holes of the top (A), making sure the brace is facing outwards.
- Insert the bolt (D) and tighten on the inside of the leg with a washer (E) and nut (F).

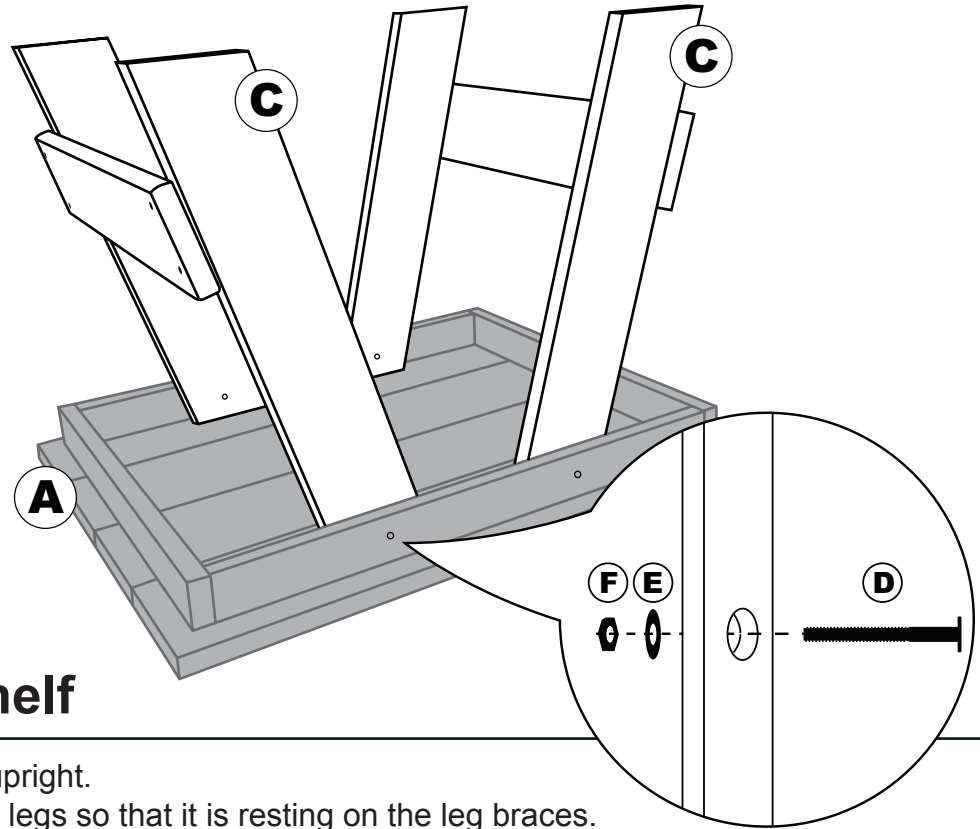

Step 2 - Bottom Shelf

- Flip the table over so it is now upright.
- Place the shelf (B) between the legs so that it is resting on the leg braces.

